

Downlight

DL

# The Downlights You Need to Seal Any Deal are All-New and Available Now.

LED



**Kenall's sealed downlights fit the needs of the most challenging environments, including:**

- Hospitals and clinics
- Behavioral health facilities
- Cleanrooms
- Containment areas
- Food processors
- Pharmaceutical manufacturers
- Transportation, transit and other public spaces
- Military installations
- Educational facilities
- All areas where damp and wet location listings simply are not enough

**Avoid the headache of downlights that don't live up to your demanding applications. Kenall's new modular downlights are designed to stay tightly sealed and perform efficiently for years.**

One simple, modular design accommodates both recessed and flush mount installations, and Ingress Protection is an integral part of that design — so there are no surprise upcharges.

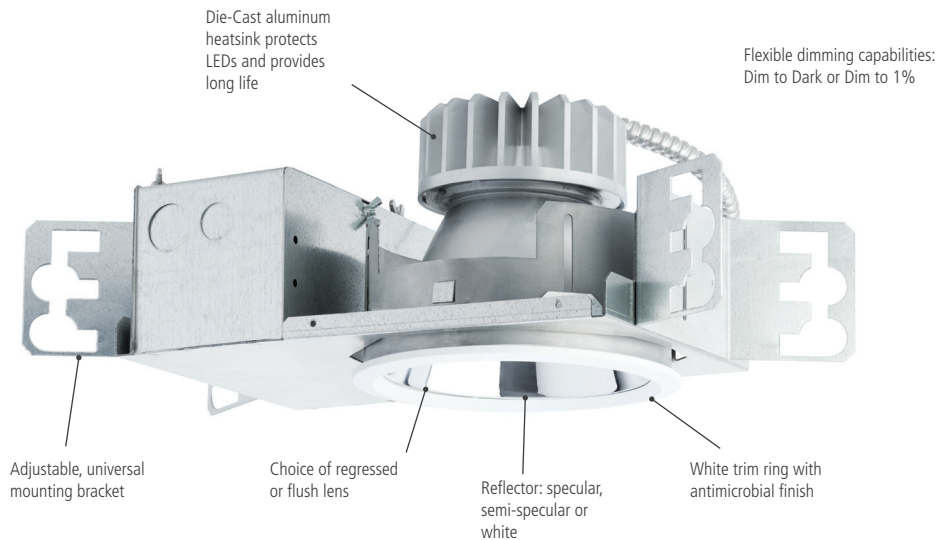

### ...And Easy Installation

This downlight ships in two phases so the rough-in frame is installed first. The trim finishing section can then be installed once the ceiling is finished, adjusting to fit various ceiling thicknesses.

# The Downlights You Need to Seal any Deal are All-New and Available Now.

LED

REGRESSED LENS DOWNLIGHTS							
MODEL	APPLICATION	INPUT WATTS	CCT	CRI	IP RATING	EMISSIONS PROTECTION	TRIM RING
Millenium™ HADL	High abuse	12L, 22L, 33L, 55L	4000K*	80 (option for 90)	IP64 with screwless flush lens, IP65 with standard flush lens		Die-cast aluminum; Stainless steel; antimicrobial white
MedMaster™ M4DL	Surgical suites	12L, 22L, 33L, 55L	3000K	80 (option for 90)	IP64	EMI Filter	Stainless steel; antimicrobial white
MedMaster™ MRIDL	MRI suites	12L, 22L, 33L, 55L	4000K*	80 (option for 90)	IP64	24V DC RF-EMI emissions compliant	Die-cast aluminum
MedMaster™ MDL	Healthcare (general)	12L, 22L, 33L, 55L	4000K*	80 (option for 90)	IP64		Antimicrobial white
Millenium™ HADL	Education	12L, 22L, 33L, 55L	4000K*	80 (option for 90)	IP64		

FLUSH LENS DOWNLIGHTS							
MODEL	APPLICATION	INPUT WATTS	CCT	CRI	IP RATING	EMISSIONS PROTECTION	TRIM RING
MightyMac™ HADL	Correctional	12L, 22L, 33L, 55L	4000K*	80	IP65		Cold-rolled steel
MedMaster™ M4DL	Surgical suites	12L, 22L, 33L, 55L	3000K	80 (option for 90)	IP64 (IP65 optional)	EMI Filter	Stainless steel; antimicrobial white
MedMaster™ MRIDL	Healthcare (general)	12L, 22L, 33L, 55L	4000K*	80 (option for 90)	IP64	24V DC RF-EMI emissions compliant	Die-cast aluminum
MedMaster™ BHDL	MRI suites	12L, 22L, 33L, 55L	4000K*	80 (option for 90)	IP65		Die-cast aluminum; Stainless steel; antimicrobial white
Millenium™ HADL	Education	12L, 22L, 33L, 55L	4000K*	80 (option for 90)	IP64 (IP65 optional)		Cold-rolled steel or aluminum
SimpleSeal™ CDL	Cleanroom & containment	12L, 22L, 33L, 55L	4000K*	80 (option for 90)	IP64 with screwless flush lens, IP65 with standard flush lens		Die-cast aluminum; Stainless steel; antimicrobial white
EnviroPro™ EPDL	Food processing & pharmaceutical	12L, 22L, 33L, 55L	4000K*	80 (option for 90)	IP64 with screwless flush lens, IP65 with standard flush lens		Die-cast aluminum; Stainless steel; antimicrobial white
LuxTran™ TDL	Transit & Transportation	12L, 22L, 33L, 55L	4000K*	80	IP65		Stainless Steel
Millenium™ HADL	High abuse	12L, 22L, 33L, 55L	4000K*	80 (option for 90)	IP64 (IP65 optional)		Stainless steel or aluminum

\* Also available in 3,000K, 3,500K and 5,000K



www.kenall.com | P: 800-4-Kenall | F: 262-891-9701 | 10200 55th Street Kenosha, Wisconsin 53144, USA  
 This product complies with the Buy American Act and may be covered by patents found at www.kenall.com/patents.  
 Content of specification sheets is subject to change; please consult www.kenall.com for current product details.

A brand of Legrand  
 ©2019 Kenall Mfg. Co.