

IMPORTANT SAFEGUARDS

When using electrical equipment, basic safety precautions should always be followed, including the following:

THIS PRODUCT MUST BE INSTALLED IN ACCORDANCE WITH THE APPLICABLE INSTALLATION CODE BY A PERSON FAMILIAR WITH THE CONSTRUCTION AND OPERATION OF THE PRODUCT AND THE HAZARDS INVOLVED. DISCONNECT POWER TO ALL CIRCUITS BEFORE WIRING FIXTURE. INSTALL IN ACCORDANCE WITH ALL NATIONAL, STATE, AND LOCAL CODES. DO NOT CONNECT TO AN UNGROUNDED SUPPLY. READ ALL FIXTURE MARKINGS AND LABELS TO ENSURE CORRECT INSTALLATION OF FIXTURE. SUPPLEMENTAL INSTRUCTIONS MAY BE LOCATED ON THE FIXTURE, IN ADDITION TO THIS INSTRUCTION SHEET, REGARDING ORIENTATION, OR MOUNTING RESTRICTIONS.

SAVE THESE INSTRUCTIONS

INSTALLATION INSTRUCTIONS

1. Remove end caps (2) screws, each end.
2. Open lens by removing (6) screws. Swing lens open to detach as shown in Fig. 1.
3. Remove reflector (4) screws to access mounting and wiring holes.
4. Remove end caps (2) screws, each end.
5. Open lens by removing (6) screws. Swing lens open to detach as shown in Fig. 1.

Fig. 1

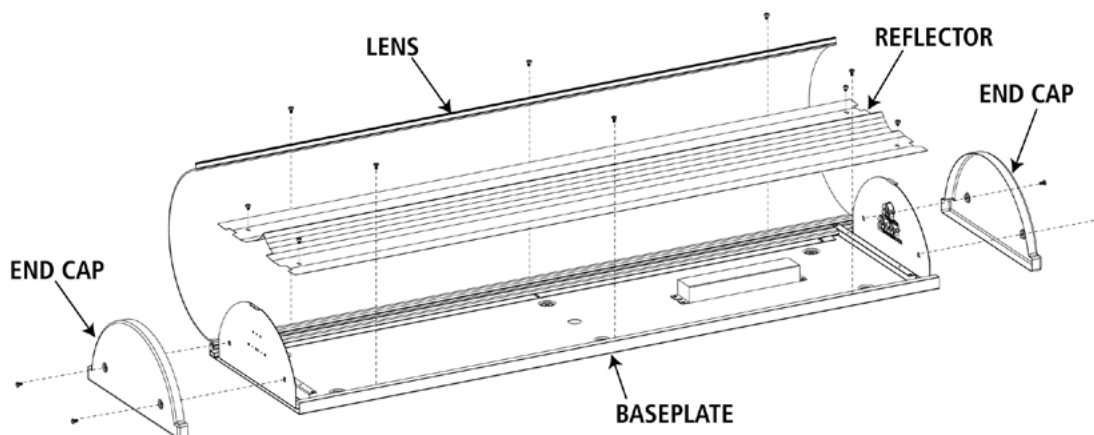
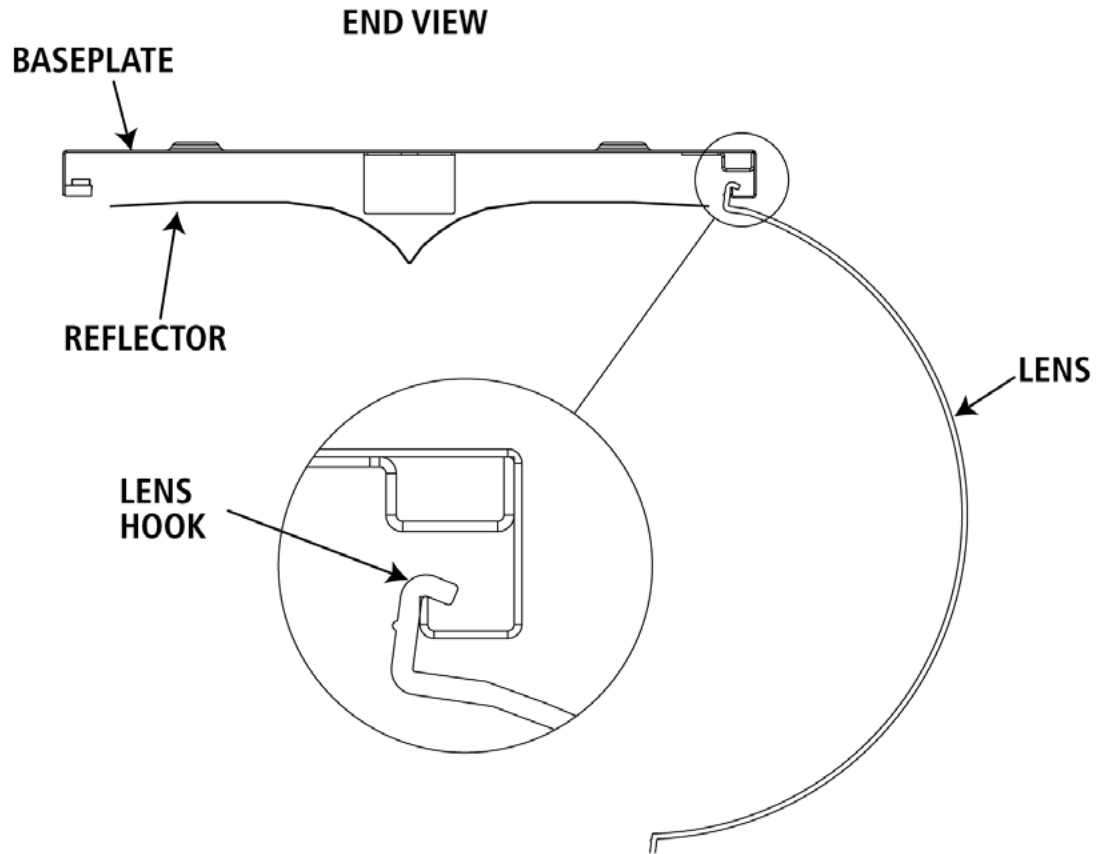

Fig. 2



CUSTOMER SERVICE

For technical assistance, call 1-800-4KENALL (1-800-453-6255).

WARRANTY

Kenall reserves the right to issue credit, repair, or replace the defective merchandise, at its discretion, upon notification and confirmation by its local representative of the defect. Kenall also reserves the right to test and examine the defective product if the defect is questionable and to deny the warranty herein for any product altered, improperly installed, installed in applications for which it is not intended. This includes operation in ambient temperatures above stated limits for any length of time. Failure by electrical surge shall not be covered under warranty.

Kenall assumes no responsibility for labor or freight costs incurred in connection with the installation, removal, or replacement of products determined to be defective or any other consequential or incidental damages arising from the use of the product. Kenall's entire liability on any claim of loss or damage resulting from a defective product is limited to the replacement price of the product.

