

YOKE INSTALLATION:

1. ALIGN CEILING SUPPORT CHANNELS WITH EDGE OF CEILING CUTOUT, THEN SECURE IN PLACE. (CHANNELS SUPPLIED BY OTHERS)
2. DRILL YOKE MOUNTING HOLES INTO CEILING SUPPORT CHANNELS, PER THE DIMENSIONS SHOWN.
3. ATTACH YOKES TO CEILING SUPPORT CHANNELS, USING SUITABLE HARDWARE. (HARDWARE SUPPLIED BY OTHERS)

UNLESS OTHERWISE SPECIFIED DIMENSIONS ARE IN INCHES TOLERANCES ARE:				CAD GENERATED DRAWING DO NOT MANUALLY UPDATE		 1020 Lakeside Drive Gurnee Illinois 60031	
FRACTIONS	DECIMALS .XX ± .05 .XXX ± .010 .XXXX ± .0015	ANGLES ± 1/2°		APPROVALS	DATE		
MATERIAL:				DRAWN		2/23/2012	
FINISH:				CHECKED		ENG. APPROVAL	
N/A				MFG. APPROVAL		SCALE: --	
N/A				DO NOT SCALE DRAWING		SIZE A DWG. CAD FILE No: F-4570	
						SHT: 1 OF: 2 REV: 0	

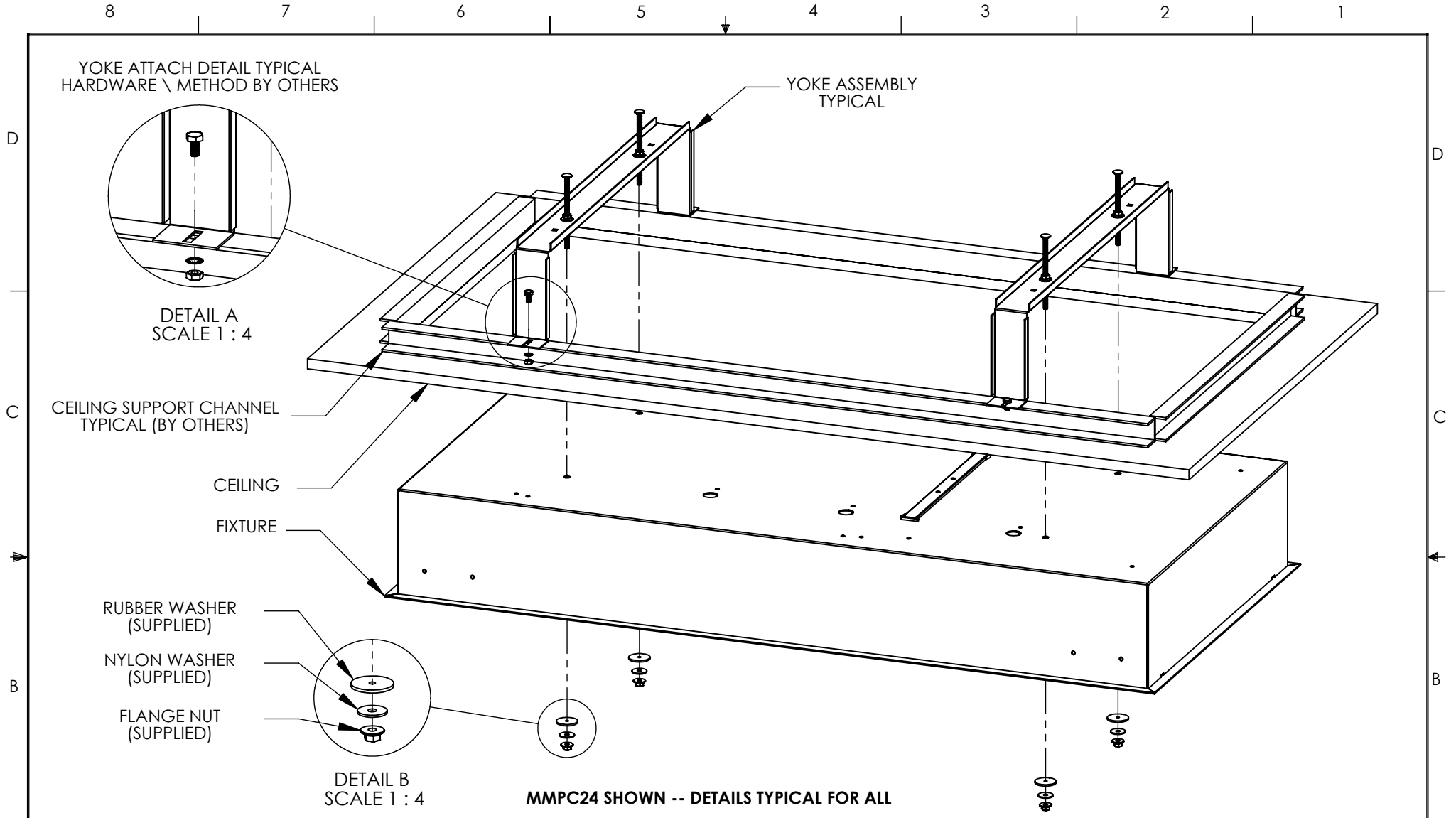

FIXTURE INSTALLATION:

1. REMOVE DOOR.
2. REMOVE FLAT REFLECTOR FROM EXAM COMPARTMENT. REMOVE DIFFUSER AND REFLECTORS FROM AMBIENT COMPARTMENT.
3. ALIGN FITURE WITH CEILING CUTOUT, AND LIFT INTO PLACE. CARRIAGE BOLTS WILL ALIGN WITH MOUNTING HOLES IN HOUSING.
4. USING SUPPLIED HARDWARE, SECURE FITURE TO YOKE ASSEMBLY.

This document contains information that is privileged, confidential or otherwise protected from use and disclosure. You are hereby notified that any review, disclosure, copying, dissemination or taking of any action in reliance on its contents or other use is strictly prohibited. This document and its contents are confidential proprietary information of Kenall Manufacturing Company.

UNLESS OTHERWISE SPECIFIED DIMENSIONS ARE IN INCHES TOLERANCES ARE:		CAD GENERATED DRAWING DO NOT MANUALLY UPDATE		 1020 Lakeside Drive Gurnee Illinois 60031	
FRACTIONS	DECIMALS .XX ± .05 .XXX ± .010 .XXXX ± .0015	ANGLES ± 1/2°	APPROVALS		
MATERIAL: N/A			DRAWN ESW	2/23/2012	INSTR SHT YOKE & FIXTURE MMPC MMIB F-4570
FINISH: N/A			CHECKED		
			ENG. APPROVAL		
			MFG. APPROVAL		SIZE A DWG. FILE No:
			SCALE: -- DO NOT SCALE DRAWING		SHT: 2 OF: 2 REV: 0