

**YOUR YOKE MAY HAVE 2 SETS OF BOLT HOLES  
MEASURE MOUNTING HOLE SPACING ON FIXTURE  
TO DETERMINE CORRECT HOLE CENTERS**

**PRE-SET "A" DIMENSION  
FOR CORRECT THREAD LENGTH  
REQUIRED FOR INSTALLED FIXTURE**

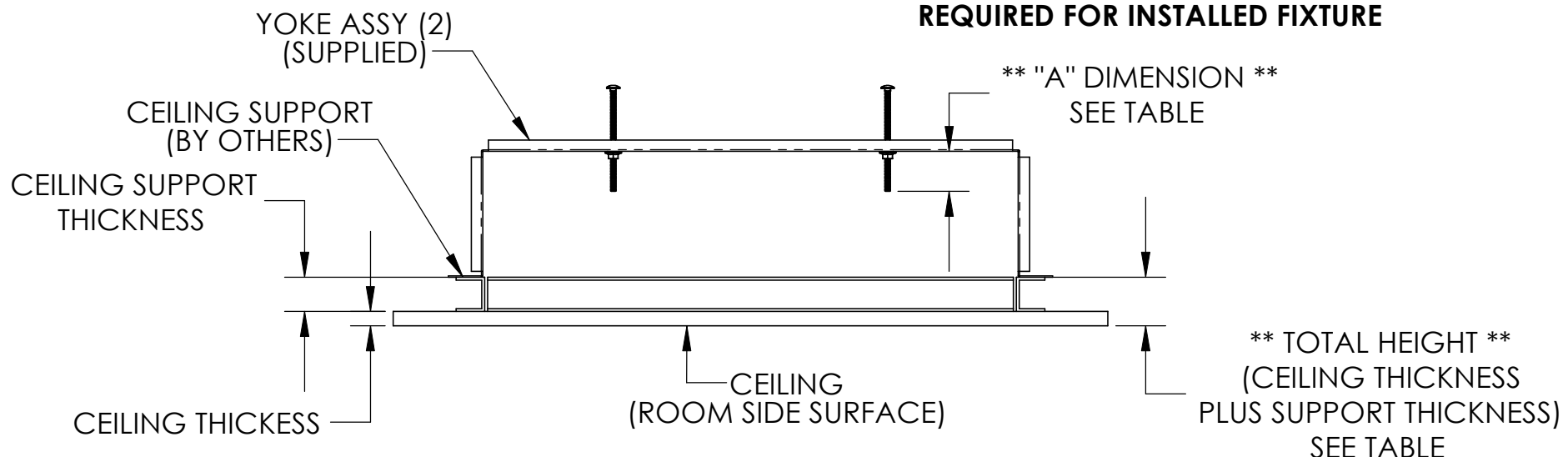

PRE-SETTING CARRIAGE BOLT "A" DIMENSION:

1. DETERMINE TOTAL HEIGHT (CEILING THICKNESS PLUS CEILING SUPPORT THICKNESS)
2. BASED ON TOTAL HEIGHT, ADJUST CARRIAGE BOLTS (4, SUPPLIED) TO "A" DIMENSION INDICATED

| TOTAL HEIGHT   | "A" DIMENSION  |
|----------------|----------------|
| 1 3/8" (1.375) | 1" (1.000)     |
| 1 5/8" (1.625) | 1 1/4" (1.250) |
| 2 1/8" (2.125) | 1 3/4" (1.750) |
| 2 5/8" (2.625) | 2 1/4" (2.250) |
| 4 1/8" (4.125) | 3 3/4" (3.750) |

This document contains information that is privileged, confidential or otherwise protected from use and disclosure. You are hereby notified that any review, disclosure, copying, dissemination or taking of any action in reliance on its contents or other use is strictly prohibited. This document and its contents are confidential proprietary information of Kenall Manufacturing Company.

|   |   |           |   |
|---|---|-----------|---|
| UNLESS OTHERWISE SPECIFIED<br>DIMENSIONS ARE IN INCHES<br>TOLERANCES ARE: | CAD GENERATED DRAWING<br>DO NOT MANUALLY UPDATE                                       |           | <br>10200 55th Street Kenosha WI 53144 |
|   | FRACTIONS:    DECIMALS:    ANGLES:    ±1/2°<br>.XX ±.05<br>.XXX ±.010<br>.XXXX ±.0015 | APPROVALS |   |
| MATERIAL:<br><br>N/A  | DRAWN   | ESW       | 2/23/2012   |
|   | CHECKED   |           |   |
| FINISH:<br><br>N/A  | ENG. APPROVAL   |           |   |
|   | MFG. APPROVAL   |           |   |
|   | SCALE: --   |           |   |
|   | DO NOT SCALE DRAWING  | SIZE A    | DWG. CAD FILE No:<br><b>F-4569</b>  |
|   |   |           | SHT: 1<br>OF: 1    REV: 0   |