

MLAS SERIES

IMPORTANT SAFEGUARDS

When using electrical equipment, basic safety precautions should always be followed, including the following:

THIS PRODUCT MUST BE INSTALLED IN ACCORDANCE WITH THE APPLICABLE INSTALLATION CODE BY A PERSON FAMILIAR WITH THE CONSTRUCTION AND OPERATION OF THE PRODUCT AND THE HAZARDS INVOLVED. DISCONNECT POWER TO ALL CIRCUITS BEFORE WIRING FIXTURE. INSTALL IN ACCORDANCE WITH ALL NATIONAL, STATE, AND LOCAL CODES. DO NOT CONNECT TO AN UNGROUNDED SUPPLY. READ ALL FIXTURE MARKINGS AND LABELS TO ENSURE CORRECT INSTALLATION OF FIXTURE. SUPPLEMENTAL INSTRUCTIONS MAY BE LOCATED ON THE FIXTURE, IN ADDITION TO THIS INSTRUCTION SHEET, REGARDING ORIENTATION, OR MOUNTING RESTRICTIONS.

SAVE THESE INSTRUCTIONS**INSTALLATION INSTRUCTIONS**

1. Remove the screw(s) from the luminaire and unhook front housing (B) from the baseplate assembly (C).
2. Remove the reflector / wireway to expose the mounting holes.
3. Remove 1.50" knockout in the center of the baseplate (C).
4. Use the baseplate (C) as a template and mark the pilot holes (E) on the mount surface. Orient the baseplate (C) with the angle bracket hook (D) at the top. NOTE: The location of the supply wire hole is not centered at the baseplate.
5. To ensure wet location rating, apply square gasket (supplied) around wire access opening and six round gaskets (supplied) on the wall side of the baseplate.
6. Using ¼-20 fasteners and anchors appropriate for the mounting surface (not supplied), mount fixture base.
7. Disconnect facility power to the electric power supply leads.

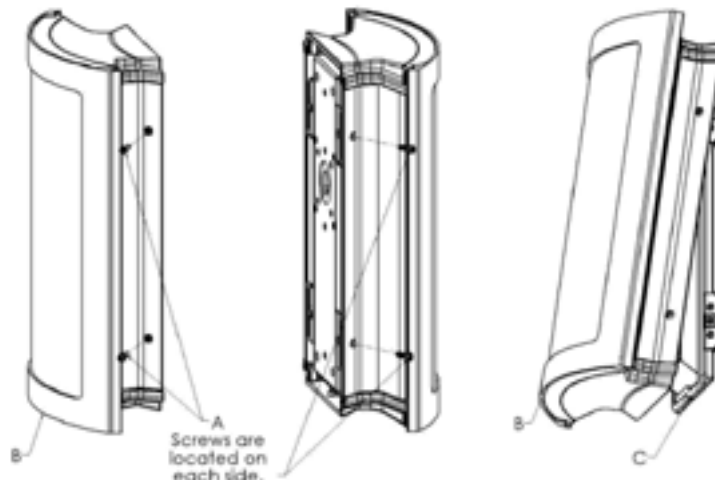
**Screw and Housing Removal**

www.kenall.com | P: 800-4-Kenall | F: 262-891-9701 | 10200 55th Street Kenosha, Wisconsin 53144, USA

A brand of **legrand**

This product complies with the Buy American Act: manufactured in the United States with more than 50% of the component cost of US origin. It may be covered by patents found at www.kenall.com/patents. Content of specification sheets is subject to change; please consult www.kenall.com for current product details. ©2019 Kenall Mfg. Co.

MLAS813_MLAS813-LED-090418

Reflector/Wireway Removal

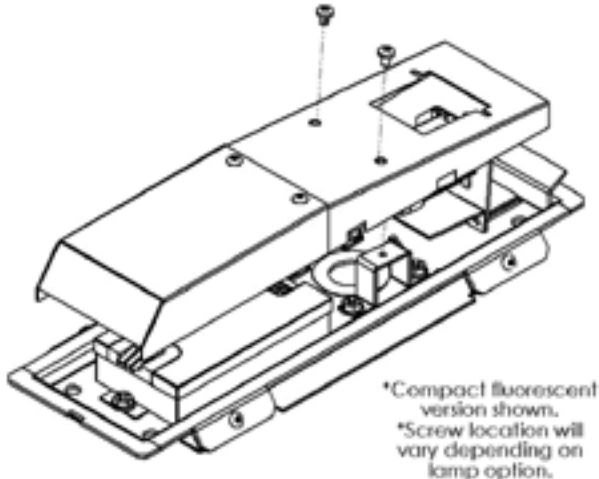

Mounting Holes

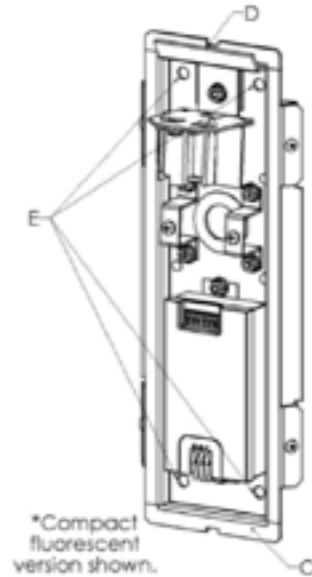

Supply Wire and Mounting Hole Locations

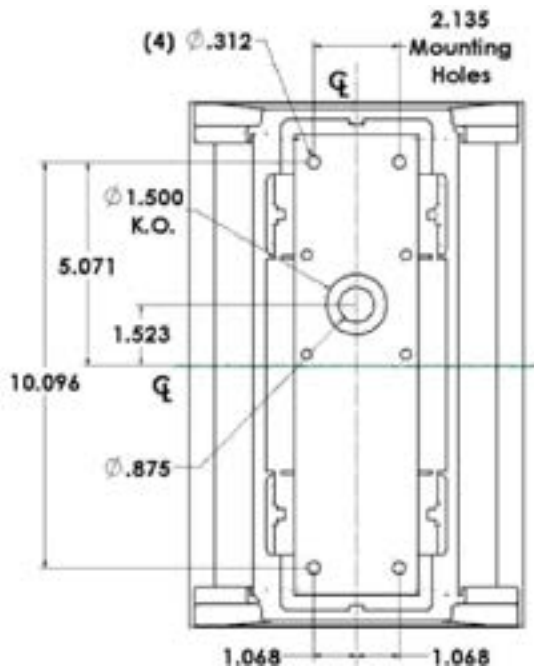

8. Connect the luminaire assembly power leads to the power supply leads. Make sure proper ground is made. Use the correct size of connectors that are applicable for the gauge and number of wires (not included).
9. Connections to be made in the junction box not in the luminaire.
10. Reattach the reflector / wireway with the screws that were removed in step 3.
11. Once the reflector / wireway are attached, install the specified lamp of the luminaire.
12. Hook the front housing (B) onto the angle bracket hook (D).
13. Replace the screw(s) removed in step 1. NOTE: Do not push on outer lens when mounting the front housing.



CUSTOMER SERVICE

For technical assistance, call 1-800-4KENALL (1-800-453-6255).

WARRANTY

For warranty information visit www.kenall.com/Resources/Certified-Performance-Warranties

