

IMPORTANT SAFEGUARDS

When using electrical equipment, basic safety precautions should always be followed, including the following:

THIS PRODUCT MUST BE INSTALLED IN ACCORDANCE WITH THE APPLICABLE INSTALLATION CODE BY A PERSON FAMILIAR WITH THE CONSTRUCTION AND OPERATION OF THE PRODUCT AND THE HAZARDS INVOLVED. DISCONNECT POWER TO ALL CIRCUITS BEFORE WIRING FIXTURE. INSTALL IN ACCORDANCE WITH ALL NATIONAL, STATE, AND LOCAL CODES. DO NOT CONNECT TO AN UNGROUNDED SUPPLY. READ ALL FIXTURE MARKINGS AND LABELS TO ENSURE CORRECT INSTALLATION OF FIXTURE. SUPPLEMENTAL INSTRUCTIONS MAY BE LOCATED ON THE FIXTURE, IN ADDITION TO THIS INSTRUCTION SHEET, REGARDING ORIENTATION, OR MOUNTING RESTRICTIONS.

CE PRODUIT DOIT ÊTRE INSTALLÉ SELON LE CODE D'INSTALLATION PERTINENT, PAR UNE PERSONNE QUI CONNAÎT BIEN LE PRODUIT ET SON FONCTIONNEMENT AINSI QUE LES RISQUES INHÉRENTS.

THE DOWNLIGHT CONTAINS SENSITIVE ELECTRONICS. TAKE CARE TO AVOID DAMAGE BY IMPROPER HANDLING OR STATIC ELECTRICITY DISCHARGE (ESD). EITHER TYPE OF DAMAGE COULD RENDER THE SYSTEM INOPERABLE OR CAUSE LATENT FAILURE.

SAVE THESE INSTRUCTIONS

Trunnion Kit

1. Assemble trunnion kits as shown using (4) ¼ - 20 x .500" screws, washers, and nuts (provided). Shown in Figure (1).
2. Attach trunnion brackets to trunnion box shown on the top of the fixture with (4) 10-32: hex nuts (provided). Shown in Figures (1 & 2).
3. Install ¾" NPT conduit hub (supplied by others) into trunnion box.
4. Make electrical connections in conduit body (supplied by others). Attach ¾" NPT conduit hub (supplied by others) between conduit and J-box.

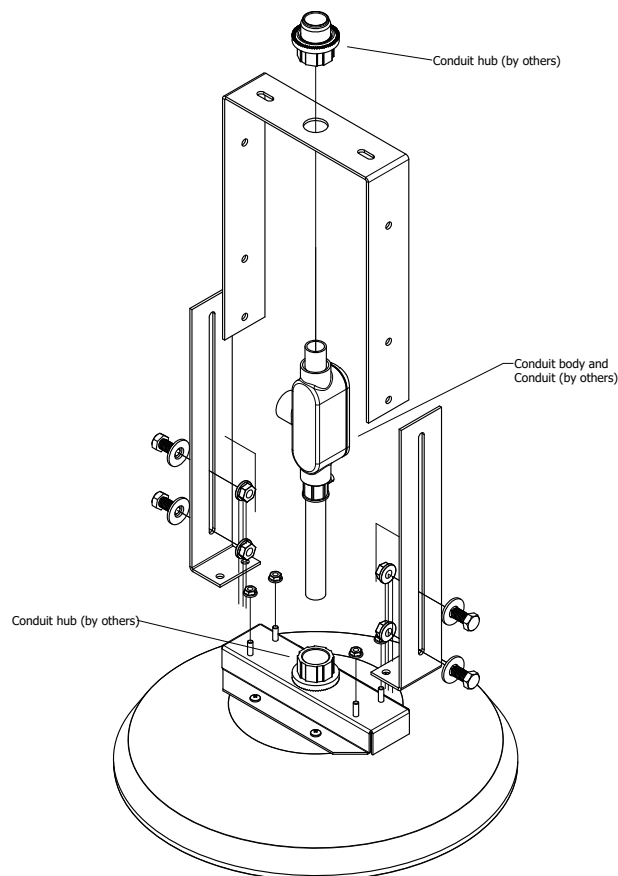

WIRING

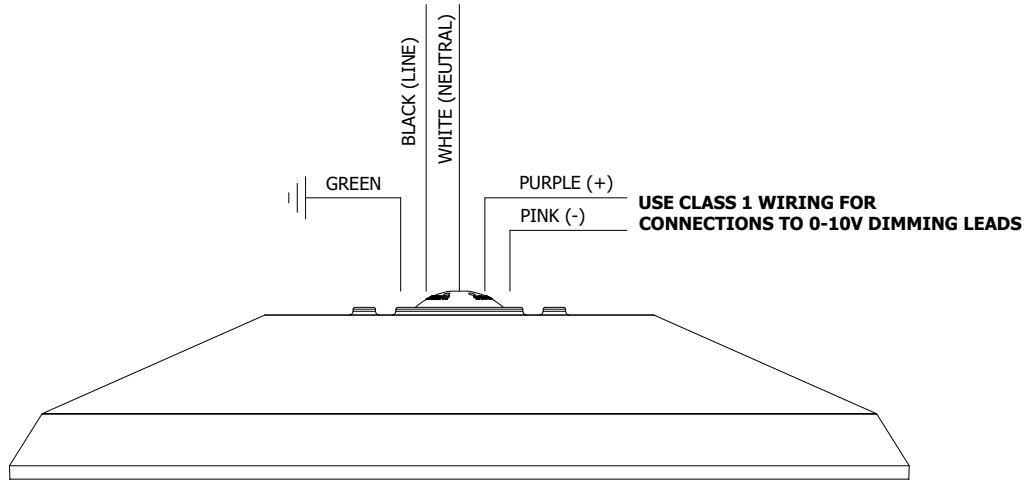

CUSTOMER SERVICE

For technical assistance, call 1-800-4KENALL (1-800-453-6255). For additional instructions, go to www.kenall.com/Installs

WARRANTY

For warranty information visit www.kenall.com/Resources/Certified-Performance-Warranties

