

### Applications

Metrex Egress METELHC Series high capacity wall surface mount unit equipment for high abuse environments. See fixture label for restrictions.

### Features

- Sealed, maintenance-free nickel-cadmium battery. Standard fixture is suitable for use in 10°C (50°F) to 45°C (113°F) environments. CEL option includes a thermostatically controlled battery warmer and is suitable for use in -30°C (-22°F) to 45°C (113°F) environments. Follow Kenall Instruction Sheet F-2929 for proper wiring of CEL option.
- Self-testing circuitry automatically conditions the battery and performs regularly scheduled tests that conform to NFPA 101 Life Safety Code. Self-diagnostic circuitry monitors battery, charger, power transfer and lamp functions.

### Installation (Figs. 1, 2, 3)

- Fixture is shipped with battery disconnected.
- Follow Kenall Instruction Sheet F-2930 for proper mounting, assembly and wiring of unit.
- After installing electrical chassis and making field wiring connections (AC power OFF), connect the two polarized 4-pin battery connectors to PC board assembly. Battery connector #1 should always be connected first and disconnected last.
- Upon connection of battery connector #2, the emergency lamps will illuminate for a few seconds and then extinguish. This signals that the batteries are properly connected and are protected from discharging until AC power is established.
- Carefully align inner cover over status/test pushbutton and indicator. Snap inner cover to electrical chassis assembly.

### Start Up (Figs. 2, 3)

- Do not apply power to fixture unless supply can be maintained for at least 7 days without interruption.
- If one or more batteries are not connected when power is applied, the self-diagnostic feature will detect the missing battery and the status LED will display a steady red signal. Connect the batteries in the proper sequence and reset the system by pressing and holding the manual test pushbutton for approximately 7 seconds.

### Battery Conditioning

- Upon initial power-up, the fixture will supply a trickle charge to the batteries for 90 minutes. Then it will switch to full charge mode for approximately 24 hours. The fixture will then condition the batteries with a pair of 90 minute discharge and 24 hour recharge cycles.

### Load Learning (Fig. 3)

- During the final discharge/recharge cycle of the battery conditioning function, the self-diagnostic feature will measure the operating current of the internal and external (if equipped) emergency lamps and any external LED exit signs.

**CAUTION: To avoid electrical overload, total connected lamp load (factory and field installed) should not exceed output rating.**

- Any time the total emergency lamp load (internal or external) or any remote exit sign load is intentionally altered, the system must be reset by pressing and holding the manual test pushbutton for approximately 7 seconds. Failure to do so will result in a lamp fault indication.

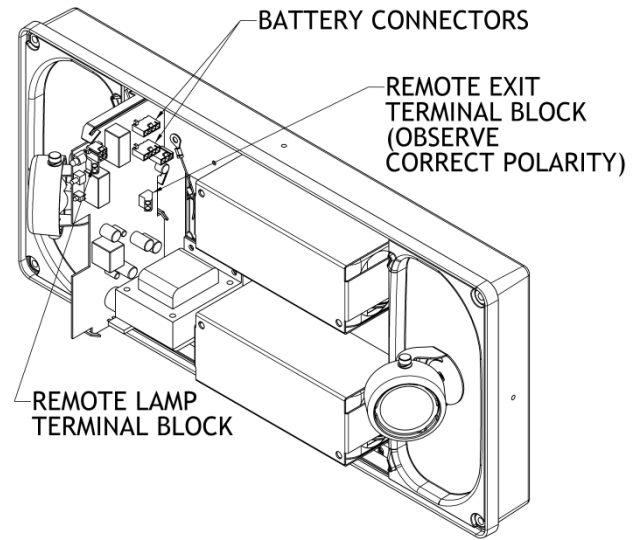

Figure 1

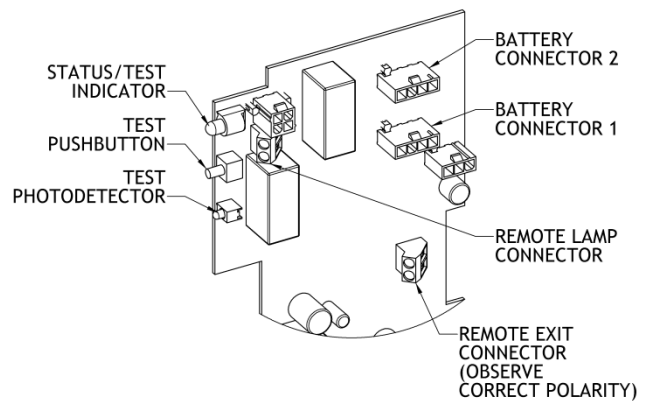

Figure 2

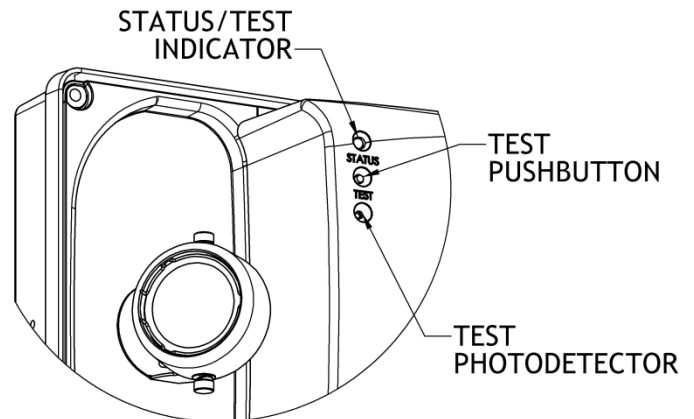

Figure 3

## Normal Operation

Normal operation is indicated by a steady green signal from the status LED. This indicates the fully charged batteries are receiving a maintenance (trickle) charge and normal AC power is present. The normally off emergency lamps will be off and any normally on remote exit signs will operate from normal AC power.

## User Initiated Tests (Fig. 3)

- A single momentary actuation of the laser-activated photodetector (see fig.1) or the manual test pushbutton will initiate a one-minute test. The normally off emergency lamps will come on and the status LED will display single green flashes, signaling a test is in progress.
- Within the first 5 seconds, pressing the manual test pushbutton twice will change the test duration to 30 minutes, three times for 60 minutes, or four times for 90 minutes.
- Actuating the photodetector or the manual test pushbutton after the first 5 seconds will cancel any user initiated test.

## Automatic Tests (Fig. 3)

- Automatic tests meet or exceed requirements of NFPA 101 Life Safety Code, Section 4.6, Article 7.9.3:  
Monthly Test 30 minute cycle every 30 days.
- These tests allow the self-diagnostic circuit to monitor battery discharge and power transfer functions and exercise the batteries to optimize their capacity. The normally off emergency lamps will come on and the status LED will display single green flashes, signaling a test is in progress.
- Actuating the TESTPHOTODETECTOR or the manual TEST PUSHBUTTON after the first 5 seconds will cancel any automatic test and delay by 12 hours all subsequent automatic tests.

## Emergency Operation

- When the AC voltage drops below a predetermined level either due to a power failure or a brownout condition, the unit will switch to emergency operation. The status LED will turn off, signaling normal AC power is not present. Unit will remain in emergency operation for 10 minutes after resumption of normal AC power to allow normal lighting systems to return to full brightness.
- Upon resumption of normal operation there will be a 90 minute time delay before a full charge is applied to the batteries to allow the unit to reach normal operating temperature (CEL option). During full charge the status LED will display two green flashes. The charger will return depleted batteries to full capacity within 24 hours. When the batteries have reached full capacity, maintenance (trickle) charging begins and the status LED will display steady green.
- In the event of a prolonged power outage, the batteries are protected from deep discharge by a low voltage disconnect circuit.

## Status Indicator (Figs. 3, 4)

A single dual-color status/fault LED is provided to allow monitoring of the circuit function. See fig. 2.

## Self-Diagnostics (Figs. 3, 4)

**Battery:** The battery condition is constantly monitored during normal operation, tests and charge cycles. A malfunctioning or end-of-life battery will terminate any charge or test and return the unit to normal operation. The status indicator will display steady red.

**Emergency Lamps:** The emergency lamp condition is constantly monitored during test cycles. A variation of more than 10% of nominal load current will cause the status indicator to display single red flashes.

**Remote Exits (if equipped):** The LED lamp condition is constantly monitored during normal operation and test cycles. A variation of more than 25% of nominal load current will cause the status indicator to display two red flashes.

**Charger:** The charger function is constantly monitored during battery charging. A charger malfunction will terminate the charge and return the unit to normal operation. The status indicator will display three red flashes.

**Transfer:** The normal-to-emergency and emergency-to-normal power transfer functions are monitored at the beginning and end of each test cycle. A transfer circuit malfunction will cause the status indicator to display four red flashes.

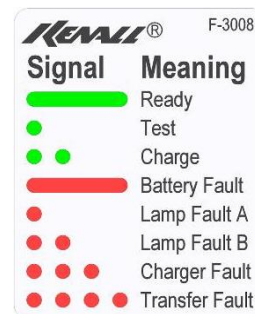

Figure 4

GREEN Status Indications	
On	Normal AC Power Operation (Maintenance Charge)
Off	AC Power Not Present (Blackout/Brownout)
One Flash	Test in Progress, User Initiated or Automatic
Two Flashes	Recovery Charge in Progress
RED Fault Indications	
On	Battery Disconnect/Fault Detected
One Flash	Emergency Lamp Fault Detected
Two Flashes	Remote Exit Fault Detected (If Equipped)
Three Flashes	Battery Charger Fault Detected
Four Flashes	Load Transfer Fault Detected

1020 Lakeside Drive, Gurnee IL 60031  
1-800-4KENALL Fax: (847) 360-1781

F-2931 Rev. 1

Kenall Manufacturing Co .  
5/26/09

[www.kenall.com](http://www.kenall.com)

**KENALL**