

## IMPORTANT SAFEGUARDS

When using electrical equipment, basic safety precautions should always be followed, including the following:

### READ AND FOLLOW ALL SAFETY INSTRUCTIONS

- Do not mount near gas or electric heaters.
- Equipment should be mounted in locations and at heights where it will not be readily subject to tampering by unauthorized personnel.
- The use of accessory equipment not recommended by the manufacturer may cause an unsafe condition.
- Caution: Halogen cycle lamps are used in this equipment. To avoid shattering: Do not operate lamp in excess of rated voltage, protect lamp against abrasion and scratches and against liquids when lamp is operating, dispose of lamp with care.
- Halogen cycle lamps operate at high temperatures. Do not store or place flammable materials near lamp.
- Do not use this equipment for other than intended use.
- Servicing of this equipment should be performed by qualified personnel.

### SAVE THESE INSTRUCTIONS

#### Applications

Metrex Egress METELHC Series wall surface mount unit equipment for high abuse environments. See fixture label for restrictions.

**THIS PRODUCT MUST BE INSTALLED IN ACCORDANCE WITH THE APPLICABLE INSTALLATION CODE BY A PERSON FAMILIAR WITH THE CONSTRUCTION AND OPERATION OF THE PRODUCT AND THE HAZARDS INVOLVED. FOLLOW ANY SPECIFIC INSTRUCTIONS ON LUMINAIRE LABELS.**

#### Preparation

- Read all fixture markings and labels to insure correct installation of the fixture. Additional information may be located on the fixture or in supplemental instructions sheets, separate from this instruction sheet, regarding orientation, mounting restrictions and optional equipment.
- For Peace of Mind Warranty, fixture must be mounted to building with at least 4 fasteners (4 point mounting). Attachment to the electrical box only is NOT recommended.
- **WARNING:** Disconnect power to the circuit before wiring fixture.
- Minimum 12" supply wire pigtailed must extend from electrical junction box for field connections within fixture enclosure.

#### Installation

**Disassembly** (Fig.1): Remove SHIELD by loosening (4) CAPTIVE SCREWS at corners. Remove INNER COVER by disengaging snaps where shown. Remove (4) CHASSIS SCREWS and set aside for reuse. Remove ELECTRICAL CHASSIS assembly.

**Mounting** Place HOUSING over an installed electrical junction box (drill points provided for temporary j-box attachment prior to permanent mounting). Locate and drill 4 pilot holes in mounting surface using HOUSING as a template. (Fig.2): For wet location installation, attach self-adhesive pad GASKETS to HOUSING at (4) mounting holes and center wiring hole. Using ¼" fasteners and anchors appropriate for the mounting surface (not supplied), attach HOUSING to structure.

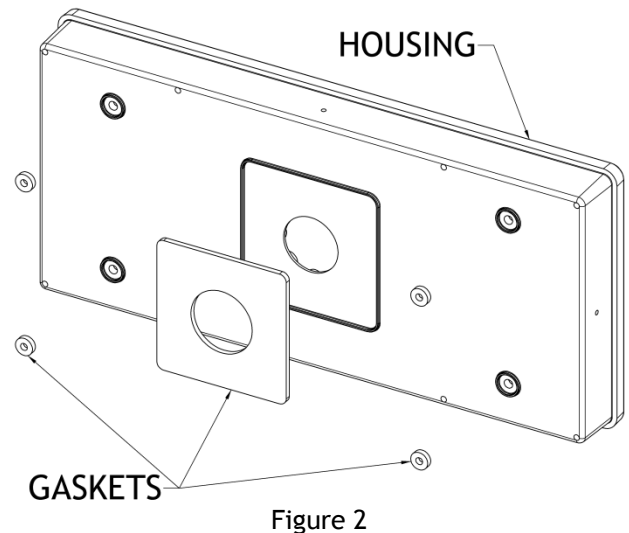
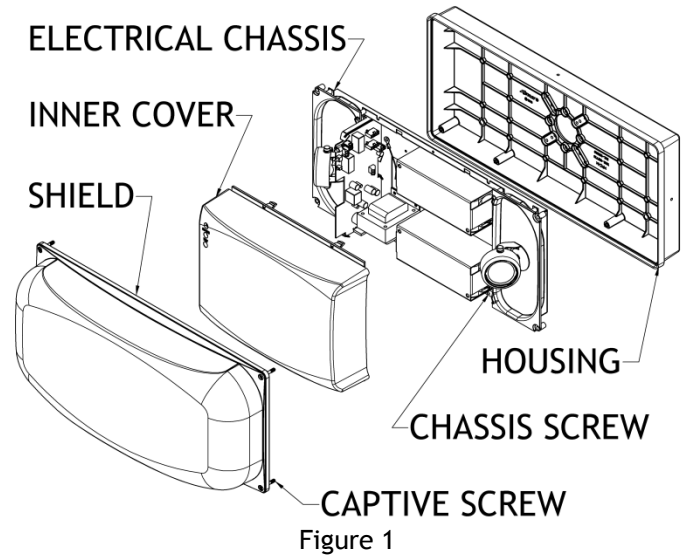

**Conduit Attachment** (Fig. 3) ½” trade size conduit may be used for power entry into top, bottom or sides of HOUSING. Locate suitable drill point and drill 7/8” dia. hole. Use proper conduit hub and locknut for wet or damp/dry location installation (not supplied).

**Wiring** (Figs. 1, 4, 5): Reinstall ELECTRICAL CHASSIS assembly using the CHASSIS SCREWS, routing 12” supply wire pigtails through opening in GEAR TRAY. Connect supply ground to GROUND WIRE provided. Connect supply wires to appropriate TRANSFORMER leads. Lead color coding: White= Neutral, Black= 120V, Orange= 277V, Blue= 347V. Separately cap off all unused leads. Connect remote loads (if used) to appropriate terminal blocks.

**CAUTION:** To avoid electrical overload, total connected lamp load (factory and field installed) should not exceed output rating.

Battery	Internal Lamps	Maximum Remote Lamp Load	
		12VDC Emergency	4VDC Exit Signs
24N	2X6.5L	11W	2
	2X12H	N.A.	
	4X6.5L	N.A.	
40N	2X6.5L	27W	
	2X12H	16W	
	2X20H	N.A.	
48N	4X6.5L	14W	
	2X12H	24W	
	2X20H	8W	
80N	4X12H	N.A.	
	2X12H	56W	
	2X20H	40W	
	4X12H	32W	
	4X20H	N.A.	

Refer to Kenall document F-2931 Metrex Egress METELHC Operation Instructions for more information.

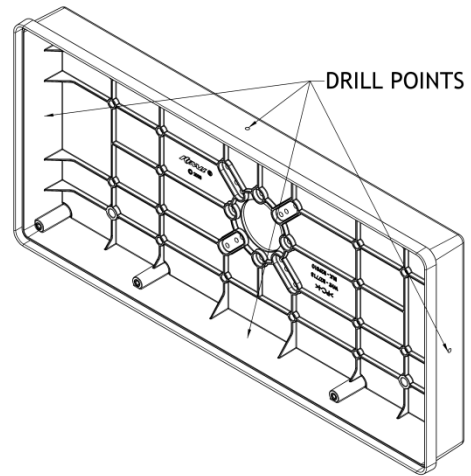

Figure 3

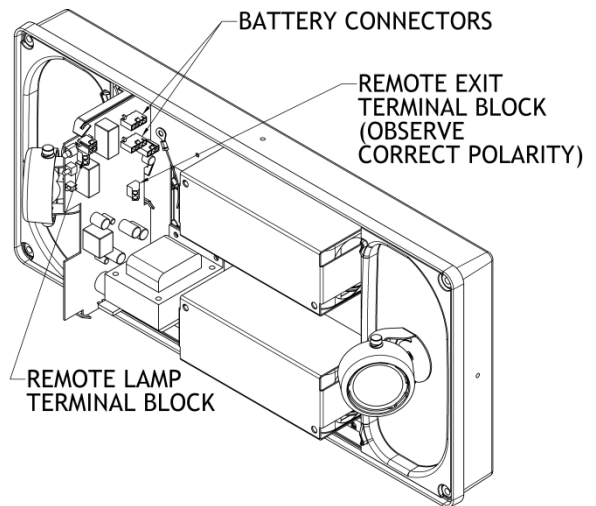

Figure 4

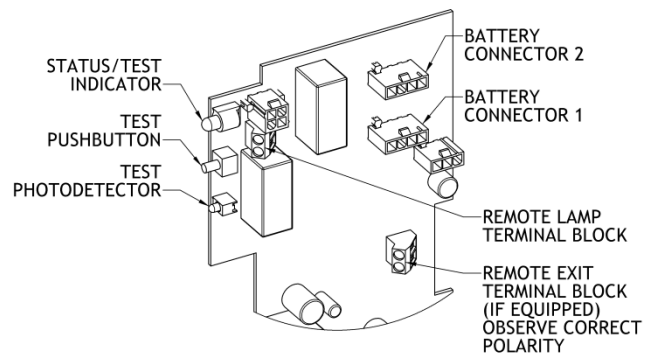

Figure 5

## WARRANTY

This product is warranted by Kenall to be free of defects in workmanship and materials for a period of one year from the date of invoice. Electrical components, including but not limited to transformers, circuit board assemblies, LED lamps and batteries are warranted for a period of three years from the date of invoice. Additionally, Kenall will replace shields, housings or mounting canopies rendered inoperable by physical abuse any time during their product life free of charge. A toll-free hot-line number, 1-800-331-1416 is provided for immediate resolution of any field problems encountered in connection with the use of Kenall's exclusive high abuse lighting products.

Kenall reserves the right to issue credit, repair, or replace the defective merchandise, at its option, upon notification and confirmation by its local representative of the defect. Kenall also reserves the right to examine the defective product if the defect is questionable and to deny the warranty herein for any product altered, improperly installed, or installed in applications for which it is not intended.

Kenall assumes no responsibility for labor or freight costs incurred in connection with the installation, removal, or replacement of products determined to be defective or any other consequential or incidental damages arising from the use of the product. Kenall's entire liability on any claim of loss or damage resulting from a defective product is limited to the replacement price of the product.

The foregoing warranty is exclusive of all other warranties and no other warranties of any kind are expressed or implied.

**Kenall Manufacturing Co.**      [www.kenall.com](http://www.kenall.com)  
5/26/09

---

1020 Lakeside Drive, Gurnee IL 60031      F-2930 Rev. 2  
1-800-4KENALL      Fax: (847) 360-1781

